

the industry standard



Handbook of Formulae and Physical Constants

For The Use Of Students And Examination Candidates

***Duplication of this material for student
in-class use or for examination
purposes is permitted without written
approval.***

***Approved by the Interprovincial Power Engineering
Curriculum Committee and the Provincial Chief
Inspectors' Association's Committee for the
standardization of Power Engineer's Examinations in
Canada.***

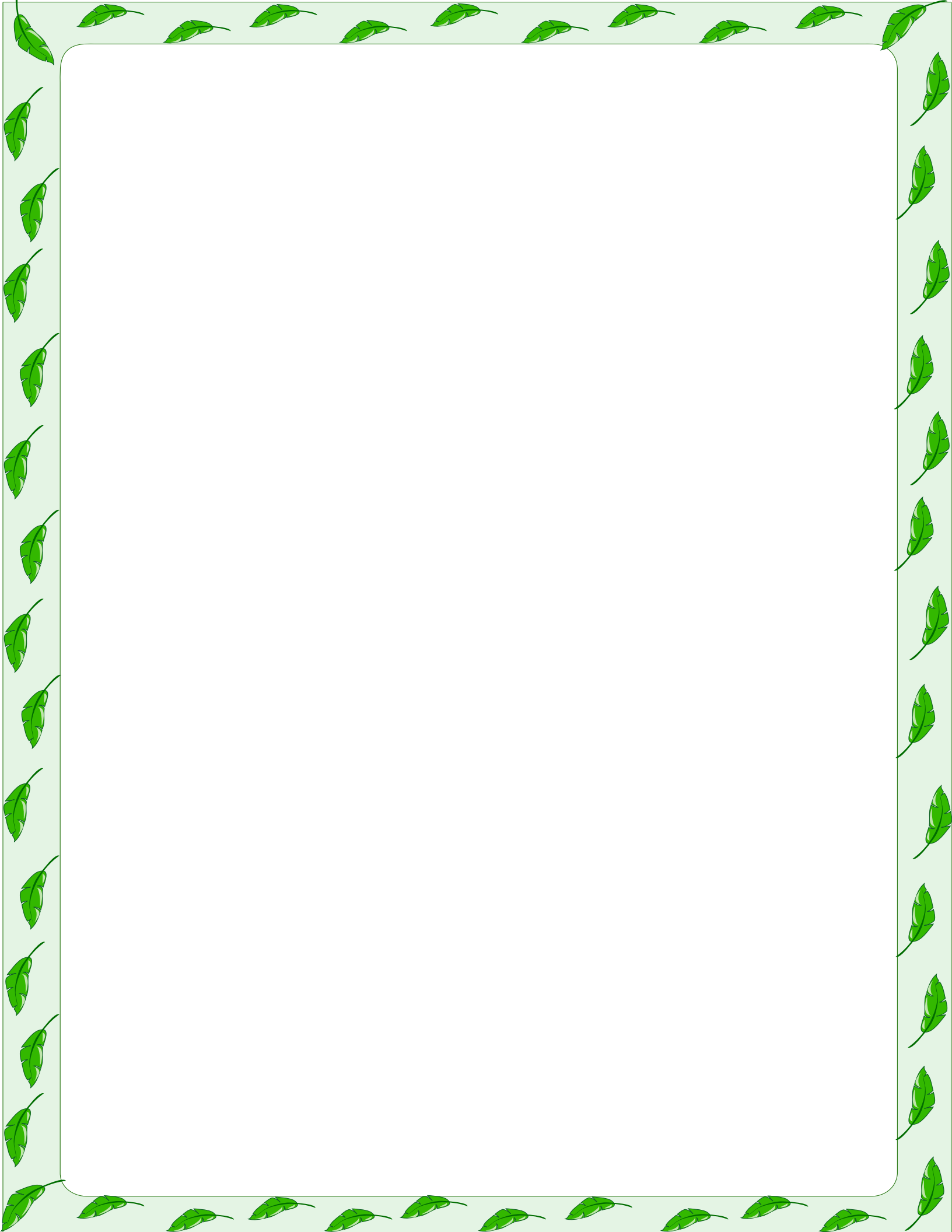

Table of Contents

<u>TOPIC</u>	<u>PAGE</u>
SI Multiples.....	1
Basic Units (distance, area, volume, mass, density).....	2
Mathematical Formulae	5
Applied Mechanics	10
Thermodynamics.....	21
Fluid Mechanics.....	28
Electricity	30
Periodic Table	34

Names in the Metric System

VALUE	EXPONENT	SYMBOL	PREFIX
1 000 000 000 000	10^{12}	T	tera
1 000 000 000	10^9	G	giga
1 000 000	10^6	M	mega
1 000	10^3	k	kilo
100	10^2	h	hecto
10	10^1	da	deca
0.1	10^{-1}	d	deci
0.01	10^{-2}	c	centi
0.001	10^{-3}	m	milli
0.000 001	10^{-6}	μ	micro
0.000 000 001	10^{-9}	n	nano
0.000 000 000 001	10^{-12}	p	pico

Conversion Chart for Metric Units

	To Milli-	To Centi-	To Deci-	To Metre, Gram, Litre	To Deca-	To Hecto-	To Kilo-
To Convert	Kilo-	$\times 10^6$	$\times 10^5$	$\times 10^4$	$\times 10^3$	$\times 10^2$	$\times 10^1$
	Hecto-	$\times 10^5$	$\times 10^4$	$\times 10^3$	$\times 10^2$	$\times 10^1$	$\times 10^{-1}$
	Deca-	$\times 10^4$	$\times 10^3$	$\times 10^2$	$\times 10^1$	$\times 10^{-1}$	$\times 10^{-2}$
	Metre, Gram, Litre	$\times 10^3$	$\times 10^2$	$\times 10^1$		$\times 10^{-1}$	$\times 10^{-2}$
	Deci-	$\times 10^2$	$\times 10^1$		$\times 10^{-1}$	$\times 10^{-2}$	$\times 10^{-3}$
	Centi-	$\times 10^1$		$\times 10^{-1}$	$\times 10^{-2}$	$\times 10^{-3}$	$\times 10^{-4}$
	Milli-		$\times 10^{-1}$	$\times 10^{-2}$	$\times 10^{-3}$	$\times 10^{-4}$	$\times 10^{-5}$

BASIC UNITS

SI

IMPERIAL

DISTANCE

1 metre (1 m) = 10 decimetres (10 dm)
= 100 centimetres (100 cm)
= 1000 millimetres (1000 mm)

1 decametre (1 dam) = 10 m
1 hectometre (1 hm) = 100 m
1 kilometre (1 km) = 1000 m

12 in. = 1 ft
3 ft = 1 yd
5280 ft = 1 mile
1760 yd = 1 mile

Conversions:

1 in. = 25.4 mm
1 ft = 30.48 cm
1 mile = 1.61 km
1 yd = 0.914 m
1 m = 3.28 ft

Area

1 sq metre (1 m²) = 10 000 cm²
= 1 000 000 mm²
1 sq hectometre (1 hm²) = 10 000 m²
= 1 hectare (1 ha)
1 sq km (1 km²) = 1 000 000 m²

1 ft² = 144 in.²
1 yd² = 9 ft²
1 sq mile = 640 acre = 1 section

Conversions:

1 in.² = 6.45 cm² = 645 mm²
1 m² = 10.8 ft²
1 acre = 0.405 ha
1 sq mile = 2.59 km²

SI**IMPERIAL****Volume**

$$1 \text{ m}^3 = 1\,000\,000 \text{ cm}^3$$

$$= 1 \times 10^9 \text{ mm}^3$$

$$1 \text{ dm}^3 = 1 \text{ litre}$$

$$1 \text{ litre} = 1000 \text{ cm}^3$$

$$1 \text{ mL} = 1 \text{ cm}^3$$

$$1 \text{ m}^3 = 1000 \text{ litres}$$

$$1 \text{ ft}^3 = 1728 \text{ in.}^3$$

$$1 \text{ yd}^3 = 27 \text{ ft}^3$$

$$1 \text{ (liquid) U.S. gallon} = 231 \text{ in.}^3$$

$$= 4 \text{ (liquid) quarts}$$

$$1 \text{ U.S. barrel (bbl)} = 42 \text{ U.S. gal.}$$

$$1 \text{ imperial gallon} = 1.2 \text{ U.S. gal.}$$

Conversions:

$$1 \text{ in.}^3 = 16.4 \text{ cm}^3$$

$$1 \text{ m}^3 = 35.3 \text{ ft}^3$$

$$1 \text{ litre} = 61 \text{ in.}^3$$

$$1 \text{ U.S. gal} = 3.78 \text{ litres}$$

$$1 \text{ U.S. bbl} = 159 \text{ litres}$$

$$1 \text{ litre/s} = 15.9 \text{ U.S. gal/min}$$

Mass and Weight

$$1 \text{ kilogram (1 kg)} = 1000 \text{ grams}$$

$$1000 \text{ kg} = 1 \text{ tonne}$$

$$2000 \text{ lb} = 1 \text{ ton (short)}$$

$$1 \text{ long ton} = 2240 \text{ lb}$$

Conversions:

1 kg (on Earth) results in a weight of 2.2 lb

Density

$$\text{mass density} = \frac{\text{mass}}{\text{volume}}$$

$$\rho = \frac{m}{V} \left(\frac{\text{kg}}{\text{m}^3} \right)$$

$$\text{weight density} = \frac{\text{weight}}{\text{volume}}$$

$$\rho = \frac{w}{V} \left(\frac{\text{lb}}{\text{ft}^3} \right)$$

Conversions:

(on Earth) a mass density of $1 \frac{\text{kg}}{\text{m}^3}$ results in a weight density of $0.0623 \frac{\text{lb}}{\text{ft}^3}$



SI**Imperial****RELATIVE DENSITY**

In SI R.D. is a comparison of mass density to a standard. For solids and liquids the standard is fresh water.

In Imperial the corresponding quantity is **specific gravity**; for solids and liquids a comparison of weight density to that of water.

Conversions:

In both systems the same numbers hold for R.D. as for S.G. since these are equivalent ratios.

RELATIVE DENSITY (SPECIFIC GRAVITY) OF VARIOUS SUBSTANCES

Water (fresh).....	1.00	Mica.....	2.9
Water (sea average)	1.03	Nickel	8.6
Aluminum.....	2.56	Oil (linseed)	0.94
Antimony.....	6.70	Oil (olive)	0.92
Bismuth.....	9.80	Oil (petroleum)	0.76-0.86
Brass	8.40	Oil (turpentine)	0.87
Brick	2.1	Paraffin	0.86
Calcium.....	1.58	Platinum.....	21.5
Carbon (diamond).....	3.4	Sand (dry)	1.42
Carbon (graphite).....	2.3	Silicon.....	2.6
Carbon (charcoal)	1.8	Silver.....	10.57
Chromium.....	6.5	Slate	2.1-2.8
Clay.....	1.9	Sodium.....	0.97
Coal.....	1.36-1.4	Steel (mild)	7.87
Cobalt	8.6	Sulphur	2.07
Copper	8.77	Tin.....	7.3
Cork	0.24	Tungsten	19.1
Glass (crown).....	2.5	Wood (ash)	0.75
Glass (flint).....	3.5	Wood (beech)	0.7-0.8
Gold	19.3	Wood (ebony).....	1.1-1.2
Iron (cast).....	7.21	Wood (elm).....	0.66
Iron (wrought)	7.78	Wood (lignum-vitae) ..	1.3
Lead	11.4	Wood (oak).....	0.7-1.0
Magnesium	1.74	Wood (pine).....	0.56
Manganese.....	8.0	Wood (teak)	0.8
Mercury	13.6	Zinc.....	7.0

Greek Alphabet

Alpha	α	Iota	ι	Rho	ρ
Beta	β	Kappa	κ	Sigma	Σ, σ
Gamma	γ	Lambda	λ	Tau	τ
Delta	Δ	Mu	μ	Upsilon	υ
Epsilon	ε	Nu	ν	Phi	Φ, ϕ
Zeta	ζ	Xi	ξ	Kai	χ
Eta	η	Omicron	O	Psi	ψ
Theta	θ	Pi	π	Omega	Ω, ω

MATHEMATICAL FORMULAE

Algebra

1. Expansion Formulae

$$(x + y)^2 = x^2 + 2xy + y^2$$

$$(x - y)^2 = x^2 - 2xy + y^2$$

$$x^2 - y^2 = (x - y)(x + y)$$

$$(x + y)^3 = x^3 + 3x^2y + 3xy^2 + y^3$$

$$x^3 + y^3 = (x + y)(x^2 - xy + y^2)$$

$$(x - y)^3 = x^3 - 3x^2y + 3xy^2 - y^3$$

$$x^3 - y^3 = (x - y)(x^2 + xy + y^2)$$

2. Quadratic Equation

If $ax^2 + bx + c = 0$,

$$\text{Then } x = \frac{-b \pm \sqrt{b^2 - 4ac}}{2a}$$



Trigonometry

1. Basic Ratios

$$\sin A = \frac{y}{h}, \quad \cos A = \frac{x}{h}, \quad \tan A = \frac{y}{x}$$

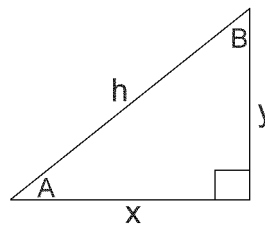

2. Pythagoras' Law

$$x^2 + y^2 = h^2$$

3. Trigonometric Function Values

Sin is positive from 0° to 90° and positive from 90° to 180°

Cos is positive from 0° to 90° and negative from 90° to 180°

Tan is positive from 0° to 90° and negative from 90° to 180°

4. Solution of Triangles

a. Sine Law

$$\frac{a}{\sin A} = \frac{b}{\sin B} = \frac{c}{\sin C}$$

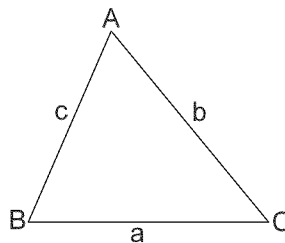

b. Cosine Law

$$c^2 = a^2 + b^2 - 2ab \cos C$$

$$a^2 = b^2 + c^2 - 2bc \cos A$$

$$b^2 = a^2 + c^2 - 2ac \cos B$$

Geometry

1. Areas of Triangles

a. All Triangles

$$\text{Area} = \frac{\text{base} \times \text{perpendicular height}}{2}$$

$$\text{Area} = \frac{bc \sin A}{2} = \frac{ab \sin C}{2} = \frac{ac \sin B}{2}$$

and,

$$\text{Area} = \sqrt{s(s-a)(s-b)(s-c)}$$

where, s is half the sum of the sides, or $s = \frac{a+b+c}{2}$

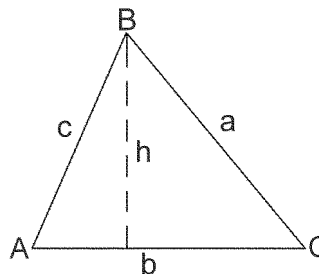

b. Equilateral Triangles

$$\text{Area} = 0.433 \times \text{side}^2$$

2. Circumference of a Circle

$$C = \pi d$$

3. Area of a Circle

$$A = \pi r^2 = \frac{\text{circumference} \times r}{2} = \frac{\pi}{4} d^2 = 0.7854 d^2$$

4. Area of a Sector of a Circle

$$A = \frac{\text{arc} \times r}{2}$$

$$A = \frac{\theta^\circ}{360} \times \pi r^2 \quad (\theta = \text{angle in degrees})$$

$$A = \frac{\theta^r}{2} \quad (\theta = \text{angle in radians})$$

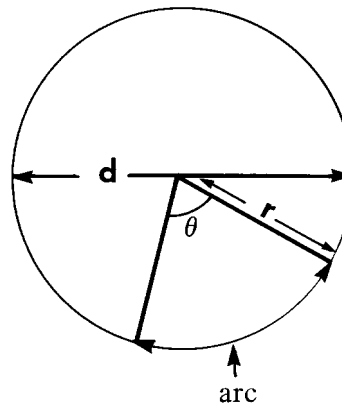

5. Area of a Segment of a Circle

$A = \text{area of sector} - \text{area of triangle}$

Also approximate area $= \frac{4}{3} h^2 \sqrt{\frac{d}{h} - 0.608}$

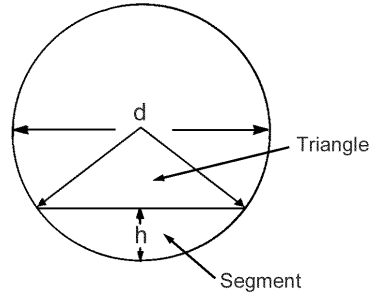

6. Ellipse

$A = \frac{\pi}{4} Dd$

Approx. circumference $= \pi \frac{(D+d)}{2}$

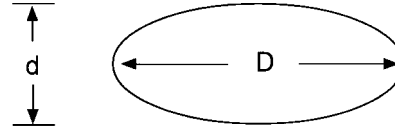

7. Area of Trapezoid

$A = \left(\frac{a+b}{2} \right) h$

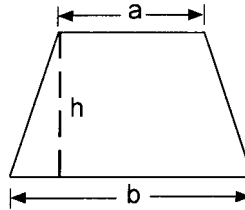

8. Area of Hexagon

$A = 2.6s^2$ where s is the length of one side

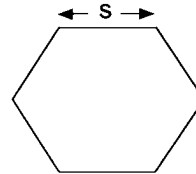

9. Area of Octagon

$A = 4.83s^2$ where s is the length of one side

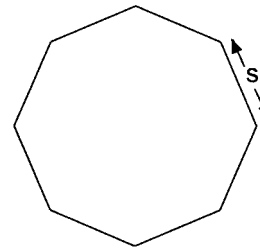

10. Sphere

Total surface area $A = 4\pi r^2$

Surface area of segment $A_s = \pi dh$

Volume $V = \frac{4}{3} \pi r^3$

Volume of segment

$V_s = \frac{\pi h^2}{3} (3r - h)$

$V_s = \frac{\pi h}{6} (h^2 + 3a^2)$ where $a = \text{radius of segment base}$

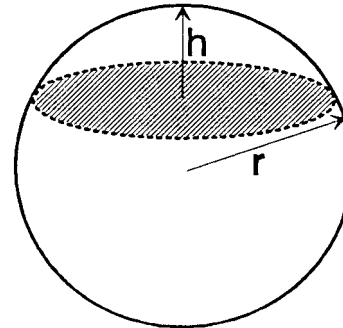

11. Volume of a Cylinder

$$V = \frac{\pi}{4} d^2 L \quad \text{where } L \text{ is cylinder length}$$

12. Pyramid

Volume

$$V = \frac{1}{3} \text{ base area} \times \text{perpendicular height}$$

Volume of frustum

$$V_F = \frac{h}{3} (A + a + \sqrt{Aa}) \quad \text{where } h \text{ is the perpendicular height, } A \text{ and } a \text{ are areas as shown}$$

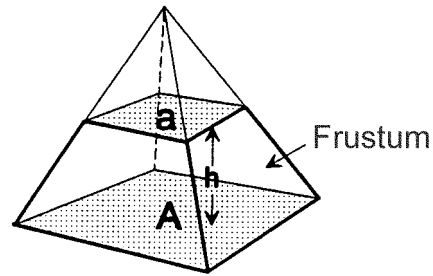

13. Cone

Area of curved surface of cone:

$$A = \frac{\pi DL}{2}$$

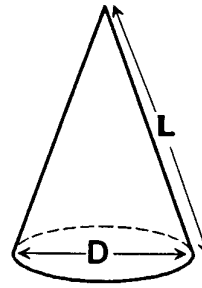

Area of curved surface of frustum

$$A_F = \frac{\pi (D + d)L}{2}$$

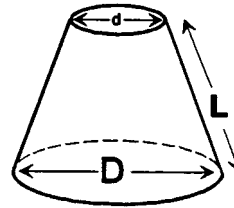

Volume of cone:

$$V = \frac{\text{base area} \times \text{perpendicular height}}{3}$$

Volume of frustum:

$$V_F = \frac{\text{perpendicular height} \times \pi (R^2 + r^2 + Rr)}{3}$$

APPLIED MECHANICS

Scalar - a property described by a magnitude only

Vector - a property described by a magnitude and a direction

Velocity - vector property equal to $\frac{\text{displacement}}{\text{time}}$

The magnitude of velocity may be referred to as **speed**

In SI the basic unit is $\frac{\text{m}}{\text{s}}$, in Imperial $\frac{\text{ft}}{\text{s}}$

Other common units are $\frac{\text{km}}{\text{h}}$, $\frac{\text{mi}}{\text{h}}$

$$\text{Conversions: } 1 \frac{\text{m}}{\text{s}} = 3.28 \frac{\text{ft}}{\text{s}}$$

$$1 \frac{\text{km}}{\text{h}} = 0.621 \frac{\text{mi}}{\text{h}}$$

Speed of sound in dry air is $331 \frac{\text{m}}{\text{s}}$ at 0°C and increases by about $0.61 \frac{\text{m}}{\text{s}}$ for each $^\circ\text{C}$ rise

Speed of light in vacuum equals $3 \times 10^8 \frac{\text{m}}{\text{s}}$

Acceleration - vector property equal to $\frac{\text{change in velocity}}{\text{time}}$

In SI the basic unit is $\frac{\text{m}}{\text{s}^2}$, in Imperial $\frac{\text{ft}}{\text{s}^2}$

$$\text{Conversion: } 1 \frac{\text{m}}{\text{s}^2} = 3.28 \frac{\text{ft}}{\text{s}^2}$$

Acceleration due to gravity, symbol "g", is $9.81 \frac{\text{m}}{\text{s}^2}$ or $32.2 \frac{\text{ft}}{\text{s}^2}$

LINEAR VELOCITY AND ACCELERATION

u initial velocity
 v final velocity
 t elapsed time
 s displacement
 a acceleration

$$v = u + at$$

$$s = \left(\frac{v + u}{2}\right)t$$

$$s = ut + \frac{1}{2}at^2$$

$$v^2 = u^2 + 2as$$

Angular Velocity and Acceleration

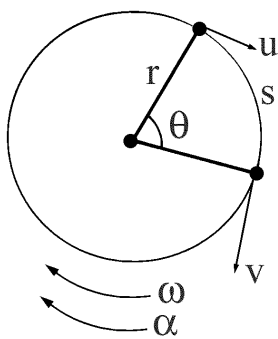

θ angular displacement (radians)
 ω angular velocity (radians/s); $\omega_1 =$ initial, $\omega_2 =$ final
 α angular acceleration (radians/s²)

$$\omega_2 = \omega_1 + \alpha t$$

$$\theta = \frac{\omega_1 + \omega_2}{2} \times t$$

$$\theta = \omega_1 t + \frac{1}{2} \alpha t^2$$

$$\omega_2^2 = \omega_1^2 + 2 \alpha \theta$$

linear displacement, $s = r \theta$

linear velocity, $v = r \omega$

linear, or tangential acceleration, $a_T = r \alpha$

Tangential, Centripetal and Total Acceleration

Tangential acceleration a_T is due to angular acceleration α

$$a_T = r\alpha$$

Centripetal (Centrifugal) acceleration a_c is due to change in direction only

$$a_c = v^2/r = r\omega^2$$

Total acceleration, a , of a rotating point experiencing angular acceleration is the vector sum of a_T and a_c

$$a = a_T + a_c$$

FORCE

Vector quantity, a push or pull which changes the shape and/or motion of an object

In SI the unit of force is the newton, N, defined as a $\frac{\text{kg m}}{\text{s}^2}$

In Imperial the unit of force is the pound lb

$$\text{Conversion: } 9.81 \text{ N} = 2.2 \text{ lb}$$

Weight

The gravitational force of attraction between a mass, m , and the mass of the Earth

In SI weight can be calculated from

$$\text{Weight} = F = mg, \quad \text{where } g = 9.81 \text{ m/s}^2$$

In Imperial, the mass of an object (rarely used), in slugs, can be calculated from the known weight in pounds

$$m = \frac{\text{Weight}}{g} \quad g = 32.2 \frac{\text{ft}}{\text{s}^2}$$

Newton's Second Law of Motion

An unbalanced force F will cause an object of mass m to accelerate a , according to:

$$F = ma \quad (\text{Imperial } F = \frac{W}{g} a, \text{ where } w \text{ is weight})$$

Torque Equation

$$T = I \alpha \quad \text{where } T \text{ is the acceleration torque in Nm, } I \text{ is the moment of inertia in } \text{kg m}^2 \text{ and } \alpha \text{ is the angular acceleration in radians/s}^2$$

Momentum

Vector quantity, symbol p ,

$$p = mv \quad (\text{Imperial } p = \frac{W}{g} v, \text{ where } w \text{ is weight})$$

in SI unit is $\frac{\text{kg m}}{\text{s}}$

Work

Scalar quantity, equal to the (vector) product of a force and the displacement of an object. In simple systems, where W is work, F force and s distance

$$W = F s$$

In SI the unit of work is the joule, J, or kilojoule, kJ

$$1 \text{ J} = 1 \text{ Nm}$$

In Imperial the unit of work is the ft-lb

Energy

Energy is the ability to do work, the units are the same as for work; J, kJ, and ft-lb

Kinetic Energy

Energy due to motion

$$E_k = \frac{1}{2}mv^2$$

In Imperial this is usually expressed as $E_k = \frac{W}{2g}v^2$ where w is weight

Kinetic Energy of Rotation

$$E_R = \frac{1}{2}mk^2\omega^2 \quad \text{where } k \text{ is radius of gyration, } \omega \text{ is angular velocity in rad/s}$$

or

$$E_R = \frac{1}{2}I\omega^2 \quad \text{where } I = mk^2 \text{ is the moment of inertia}$$

CENTRIPETAL (CENTRIFUGAL) FORCE

$$F_C = \frac{mv^2}{r} \quad \text{where } r \text{ is the radius}$$

or

$$F_C = m\omega^2 r \quad \text{where } \omega \text{ is angular velocity in rad/s}$$

Potential Energy

Energy due to position in a force field, such as gravity

$$E_p = m g h$$

In Imperial this is usually expressed $E_p = w h$ where w is weight, and h is height above some specified datum

Thermal Energy

In SI the common units of thermal energy are J, and kJ, (and kJ/kg for specific quantities)

In Imperial, the units of thermal energy are British Thermal Units (Btu)

Conversions: 1 Btu = 1055 J
 1 Btu = 778 ft-lb

Electrical Energy

In SI the units of electrical energy are J, kJ and kilowatt hours kWh. In Imperial, the unit of electrical energy is the kWh

Conversions: 1 kWh = 3600 kJ
 1 kWh = 3412 Btu = 2.66×10^6 ft-lb

Power

A scalar quantity, equal to the rate of doing work

In SI the unit is the Watt W (or kW)

$$1 \text{ W} = 1 \frac{\text{J}}{\text{s}}$$

In Imperial, the units are:

Mechanical Power - $\frac{\text{ft-lb}}{\text{s}}$, horsepower h.p.

Thermal Power - $\frac{\text{Btu}}{\text{s}}$

Electrical Power - W, kW, or h.p.

Conversions: 746 W = 1 h.p.

$$1 \text{ h.p.} = 550 \frac{\text{ft-lb}}{\text{s}}$$

$$1 \text{ kW} = 0.948 \frac{\text{Btu}}{\text{s}}$$

Pressure

A vector quantity, force per unit area

In SI the basic units of pressure are pascals Pa and kPa

$$1 \text{ Pa} = 1 \frac{\text{N}}{\text{m}^2}$$

In Imperial, the basic unit is the pound per square inch, psi

Atmospheric Pressure

At sea level atmospheric pressure equals 101.3 kPa or 14.7 psi

Pressure Conversions

$$1 \text{ psi} = 6.895 \text{ kPa}$$

Pressure may be expressed in standard units, or in units of static fluid head, in both SI and Imperial systems

Common equivalencies are:

$$1 \text{ kPa} = 0.294 \text{ in. mercury} = 7.5 \text{ mm mercury}$$

$$1 \text{ kPa} = 4.02 \text{ in. water} = 102 \text{ mm water}$$

$$1 \text{ psi} = 2.03 \text{ in. mercury} = 51.7 \text{ mm mercury}$$

$$1 \text{ psi} = 27.7 \text{ in. water} = 703 \text{ mm water}$$

$$1 \text{ m H}_2\text{O} = 9.81 \text{ kPa}$$

Other pressure unit conversions:

$$1 \text{ bar} = 14.5 \text{ psi} = 100 \text{ kPa}$$

$$1 \text{ kg/cm}^2 = 98.1 \text{ kPa} = 14.2 \text{ psi} = 0.981 \text{ bar}$$

$$1 \text{ atmosphere (atm)} = 101.3 \text{ kPa} = 14.7 \text{ psi}$$

Simple Harmonic Motion

$$\text{Velocity of P} = \omega \sqrt{R^2 - x^2} \frac{\text{m}}{\text{s}}$$

$$\text{Acceleration of P} = \omega^2 x \text{ m/s}^2$$

$$\text{The period or time of a complete oscillation} = \frac{2\pi}{\omega} \text{ seconds}$$

General formula for the period of S.H.M.

$$T = 2\pi \sqrt{\frac{\text{displacement}}{\text{acceleration}}}$$

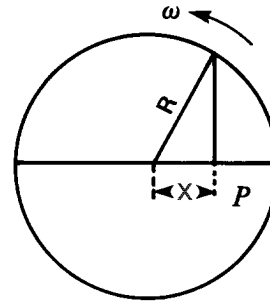

Simple Pendulum

$$T = 2\pi \sqrt{\frac{L}{g}}$$

T = period or time in seconds for a double swing

L = length in metres

The Conical Pendulum

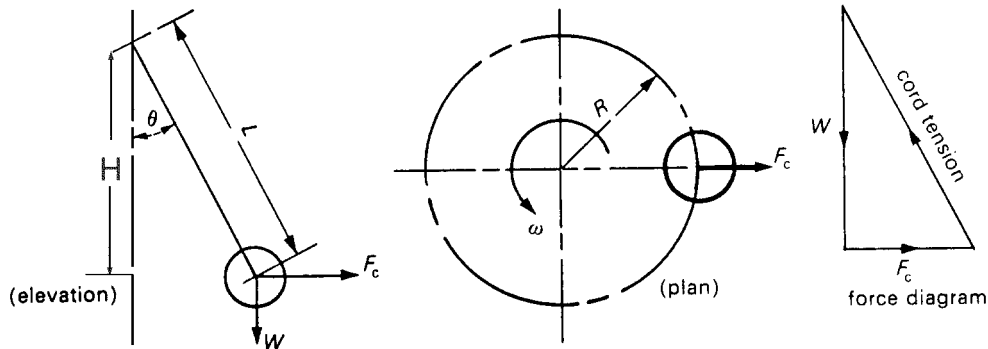

$$R/H = \tan \theta = F_c/W = \omega^2 R/g$$

Lifting Machines

W = load lifted, F = force applied

$$\text{M.A.} = \frac{\text{load}}{\text{effort}} = \frac{W}{F}$$

$$\text{V.R. (velocity ratio)} = \frac{\text{effort distance}}{\text{load distance}}$$

$$\eta = \text{efficiency} = \frac{\text{M.A.}}{\text{V.R.}}$$

1. Lifting Blocks

V.R. = number of rope strands supporting the load block

2. Wheel & Differential Axle

$$\begin{aligned} \text{Velocity ratio} &= \frac{2\pi R}{\frac{2\pi(r - r_1)}{2}} \\ &= \frac{2R}{r - r_1} \cdot 2R \end{aligned}$$

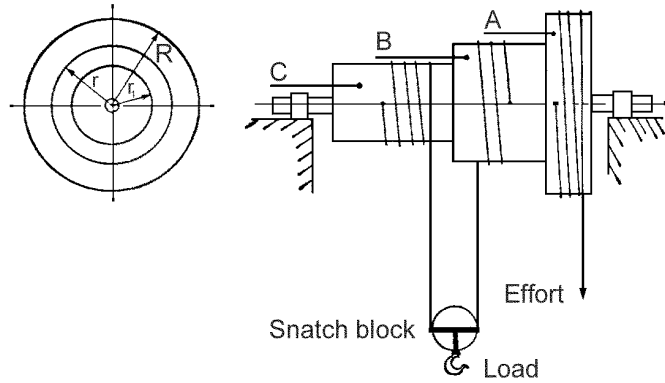

Or, using diameters instead of radii,

$$\text{Velocity ratio} = \frac{2D}{(d - d_1)}$$

3. Inclined Plane

$$\text{V.R.} = \frac{\text{length}}{\text{height}}$$

4. Screw Jack

$$\text{V.R.} = \frac{\text{circumference of leverage}}{\text{pitch of thread}}$$

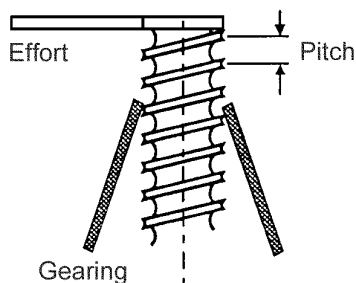

Indicated Power

I.P. = $P_m A L N$ where I.P. is power in W, P_m is mean or "average" effective pressure in Pa, A is piston area in m^2 , L is length of stroke in m and N is number of power strokes per second

Brake Power

B.P. = $T\omega$ where B.P. is brake power in W, T is torque in Nm and ω is angular velocity in radian/second

STRESS, STRAIN and MODULUS OF ELASTICITY

$$\text{Direct stress} = \frac{\text{load}}{\text{area}} = \frac{P}{A}$$

$$\text{Direct strain} = \frac{\text{extension}}{\text{original length}} = \frac{\Delta\ell}{L}$$

Modulus of elasticity

$$E = \frac{\text{direct stress}}{\text{direct strain}} = \frac{P/A}{\Delta\ell/L} = \frac{PL}{A\Delta\ell}$$

$$\text{Shear stress } \tau = \frac{\text{force}}{\text{area under shear}}$$

$$\text{Shear strain} = \frac{x}{L}$$

Modulus of rigidity

$$G = \frac{\text{shear stress}}{\text{shear strain}}$$

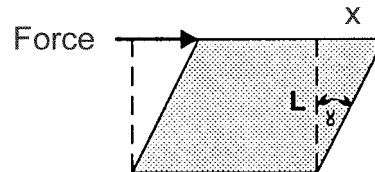
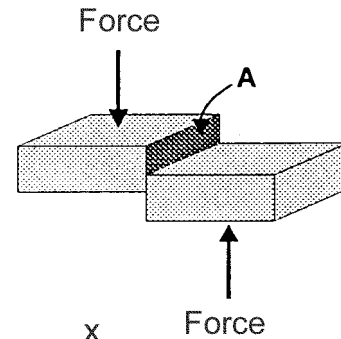
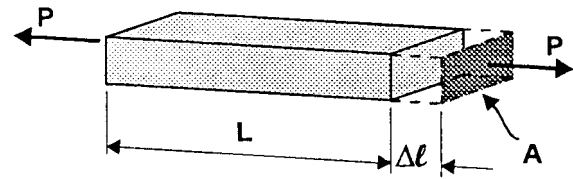

General Torsion Equation (Shafts of circular cross-section)

$$\frac{T}{J} = \frac{\tau}{r} = \frac{G \theta}{L}$$

1. For Solid Shaft

$$J = \frac{\pi}{2} r^4 = \frac{\pi d^4}{32}$$

2. For Hollow Shaft

$$J = \frac{\pi}{2} (r_1^4 - r_2^4)$$
$$= \frac{\pi}{32} (d_1^4 - d_2^4)$$

- T = torque or twisting moment in newton metres
J = polar second moment of area of cross-section about shaft axis.
 τ = shear stress at outer fibres in pascals
r = radius of shaft in metres
G = modulus of rigidity in pascals
 θ = angle of twist in radians
L = length of shaft in metres
d = diameter of shaft in metres

Relationship Between Bending Stress and External Bending Moment

$$\frac{M}{I} = \frac{\sigma}{y} = \frac{E}{R}$$

1. For Rectangle

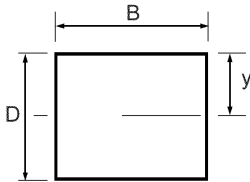

$$I = \frac{BD^3}{12}$$

- M = external bending moment in newton metres
I = second moment of area in m^4
 σ = bending stress at outer fibres in pascals
y = distance from centroid to outer fibres in metres
E = modulus of elasticity in pascals
R = radius of curvature in metres

2. For Solid Shaft

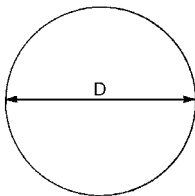

$$I = \frac{\pi D^4}{64}$$

THERMODYNAMICS

Temperature Scales

$$^{\circ}\text{C} = \frac{5}{9} (^{\circ}\text{F} - 32) \qquad ^{\circ}\text{F} = \frac{9}{5} ^{\circ}\text{C} + 32$$

$$^{\circ}\text{R} = ^{\circ}\text{F} + 460 \text{ (R Rankine)} \qquad \text{K} = ^{\circ}\text{C} + 273 \text{ (K Kelvin)}$$

Sensible Heat Equation

$$Q = mc\Delta T$$

m is mass

c is specific heat

ΔT is temperature change

Latent Heat

$$\begin{aligned} \text{Latent heat of fusion of ice} &= 335 \text{ kJ/kg} \\ \text{Latent heat of steam from and at } 100^{\circ}\text{C} &= 2257 \text{ kJ/kg} \\ \text{1 tonne of refrigeration} &= 335\,000 \text{ kJ/day} \\ &= 233 \text{ kJ/min} \end{aligned}$$

Gas Laws

1. Boyle's Law

When gas temperature is constant

$$PV = \text{constant or}$$

$$P_1V_1 = P_2V_2$$

where P is absolute pressure and V is volume

2. Charles' Law

When gas pressure is constant, $\frac{V}{T} = \text{constant}$

or $\frac{V_1}{T_1} = \frac{V_2}{T_2}$, where V is volume and T is absolute temperature

3. Gay-Lussac's Law

When gas volume is constant, $\frac{P}{T} = \text{constant}$

Or $\frac{P_1}{T_1} = \frac{P_2}{T_2}$, where P is absolute pressure and T is absolute temperature

4. General Gas Law

$$\frac{P_1 V_1}{T_1} = \frac{P_2 V_2}{T_2} = \text{constant}$$

$P V = m R T$ where P = absolute pressure (kPa)
V = volume (m³)
T = absolute temp (K)
m = mass (kg)
R = characteristic constant (kJ/kgK)

Also

$PV = nR_0T$ where P = absolute pressure (kPa)
V = volume (m³)
T = absolute temperature K
N = the number of kmoles of gas
R₀ = the universal gas constant 8.314 kJ/kmol/K

SPECIFIC HEATS OF GASES

GAS	Specific Heat at Constant Pressure kJ/kgK or kJ/kg °C	Specific Heat at Constant Volume kJ/kgK or kJ/kg °C	Ratio of Specific Heats $\gamma = c_p / c_v$
Air	1.005	0.718	1.40
Ammonia	2.060	1.561	1.32
Carbon Dioxide	0.825	0.630	1.31
Carbon Monoxide	1.051	0.751	1.40
Helium	5.234	3.153	1.66
Hydrogen	14.235	10.096	1.41
Hydrogen Sulphide	1.105	0.85	1.30
Methane	2.177	1.675	1.30
Nitrogen	1.043	0.745	1.40
Oxygen	0.913	0.652	1.40
Sulphur Dioxide	0.632	0.451	1.40

Efficiency of Heat Engines

Carnot Cycle $\eta = \frac{T_1 - T_2}{T_1}$ where T_1 and T_2 are absolute temperatures of heat source and sink

Air Standard Efficiencies

1. Spark Ignition Gas and Oil Engines (Constant Volume Cycle or Otto Cycle)

$$\eta = 1 - \frac{1}{r_v^{(\gamma-1)}} \quad \text{where } r_v = \text{compression ratio} = \frac{\text{cylinder volume}}{\text{clearance volume}}$$

$$\gamma = \frac{\text{specific heat (constant pressure)}}{\text{specific heat (constant volume)}}$$

2. Diesel Cycle

$$\eta = 1 - \frac{(R^\gamma - 1)}{r_v^{\gamma-1} \gamma (R - 1)} \quad \text{where } r = \text{ratio of compression}$$

$R = \text{ratio of cut-off volume to clearance volume}$

3. High Speed Diesel (Dual-Combustion) Cycle

$$\eta = 1 - \frac{k\beta^\gamma - 1}{r_v^{\gamma-1} [(k-1) + \gamma k(\beta-1)]}$$

$$\text{where } r_v = \frac{\text{cylinder volume}}{\text{clearance volume}}$$

$$k = \frac{\text{absolute pressure at end of constant V heating (combustion)}}{\text{absolute pressure at beginning of constant V combustion}}$$

$$\beta = \frac{\text{volume at end of constant P heating (combustion)}}{\text{clearance volume}}$$

4. Gas Turbines (Constant Pressure or Brayton Cycle)

$$\eta = 1 - \frac{1}{r_p^{\left(\frac{\gamma-1}{\gamma}\right)}}$$

THERMODYNAMIC EQUATIONS FOR PERFECT GASES (Non_Flow Processes)

Name of Process	Value of n	$P - V - T$ Relationships			Heat Added ${}_1Q_2$ kJ	Work Done ${}_1W_2$ kJ	Change In Internal Energy $U_2 - U_1$ kJ	Change In Enthalpy $H_2 - H_1$ kJ	Change In Entropy $S_2 - S_1$ kJ/K
		$P - V$	$T - P$	$T - V$					
Constant Volume $V = \text{Const.}$	∞	—	$\frac{T_1}{T_2} = \frac{P_1}{P_2}$	—	0	$m c_v (T_2 - T_1)$	$m c_p (T_2 - T_1)$	$m c_v \log_e \frac{T_2}{T_1}$	
Constant Pressure $P = \text{Const.}$	0	—	—	$\frac{T_1}{T_2} = \frac{V_1}{V_2}$	$m c_p (T_2 - T_1)$	$m c_v (T_2 - T_1)$	$m c_p (T_2 - T_1)$	$m c_p \log_e \frac{T_2}{T_1}$	
Isothermal $T = \text{Const.}$	1	$\frac{P_1}{P_2} = \frac{V_2}{V_1}$	—	—	$m R T \log_e \frac{P_1}{P_2}$	0	0	$m R \log_e \frac{P_1}{P_2}$	
Isentropic* $S = \text{Const.}$	γ	$\frac{P_1}{P_2} = \left(\frac{V_2}{V_1}\right)^\gamma$	$\frac{T_1}{T_2} = \left(\frac{P_1}{P_2}\right)^{\frac{\gamma-1}{\gamma}}$	$\frac{T_1}{T_2} = \left(\frac{V_2}{V_1}\right)^{\gamma-1}$	0	$m c_v (T_2 - T_1)$	$m c_p (T_2 - T_1)$	0	
Polytropic $P V^n = \text{Const.}$	n	$\frac{P_1}{P_2} = \left(\frac{V_2}{V_1}\right)^n$	$\frac{T_1}{T_2} = \left(\frac{P_1}{P_2}\right)^{\frac{n-1}{n}}$	$\frac{T_1}{T_2} = \left(\frac{V_2}{V_1}\right)^{n-1}$	$m c_n (T_2 - T_1)$	$m c_v (T_2 - T_1)$	$m c_p (T_2 - T_1)$	$m c_n \log_e \frac{T_2}{T_1}$	

*Can be used for reversible adiabatic processes

c_v = Specific heat at constant volume, kJ/kgK

c_p = Specific heat at constant pressure, kJ/kgK

c_n = Specific heat for a polytropic process = $c_v \left(\frac{\gamma - n}{1 - n}\right)$ kJ/kgK

H = Enthalpy, kJ

γ = Isentropic exponent, c_p/c_v

n = Polytropic exponent

P = Pressure, kPa

R = Gas content, kJ/kgK

S = Entropy, kJ/K

T = Absolute temperature, K = 273 + °C

U = Internal energy, kJ

V = Volume, m³

m = Mass of gas, kg

where r_p = pressure ratio = $\frac{\text{compressor discharge pressure}}{\text{compressor intake pressure}}$

Heat Transfer by Conduction

$$Q = \frac{\lambda A t \Delta T}{d}$$

where Q = heat transferred in joules

λ = thermal conductivity or coefficient of heat

transfer in $\frac{\text{J} \times \text{m}}{\text{m}^2 \times \text{s} \times \text{°C}}$ or $\frac{\text{W}}{\text{m} \times \text{°C}}$

A = area in m^2

t = time in seconds

ΔT = temperature difference between surfaces in °C

d = thickness of layer in m

COEFFICIENTS OF THERMAL CONDUCTIVITY

Material	Coefficient of Thermal Conductivity W/m °C
Air	0.025
Aluminum	206
Brass	104
Brick	0.6
Concrete	0.85
Copper	380
Cork	0.043
Felt	0.038
Glass	1.0
Glass, fibre	0.04
Iron, cast	70
Plastic, cellular	0.04
Steel	60
Wood	0.15
Wallboard, paper	0.076

Thermal Expansion of Solids

$$\text{Increase in length} = L \alpha (T_2 - T_1)$$

where L = original length

α = coefficient of linear expansion

$(T_2 - T_1)$ = rise in temperature

$$\text{Increase in volume} = V \beta (T_2 - T_1)$$

Where V = original volume

β = coefficient of volumetric expansion

$(T_2 - T_1)$ = rise in temperature

coefficient of volumetric expansion = coefficient of linear expansion x 3

$$\beta = 3\alpha$$

SPECIFIC HEAT and LINEAR EXPANSION OF SOLIDS

Solid	Mean Specific Heat between 0°C and 100°C kJ/kgK or kJ/kg °C	Coefficient of Linear Expansion between 0°C and 100°C (Multiply by 10 ⁻⁶)	Solid	Mean Specific Heat between 0°C and 100°C kJ/kgK or kJ/kg °C	Coefficient of Linear Expansion between 0°C and 100°C (Multiply by 10 ⁻⁶)
Aluminum	0.909	23.8	Iron (cast)	0.544	10.4
Antimony	0.209	17.5	Iron (wrought)	0.465	12.0
Bismuth	0.125	12.4	Lead	0.131	29.0
Brass	0.383	18.4	Nickel	0.452	13.0
Carbon	0.795	7.9	Platinum	0.134	8.6
Cobalt	0.402	12.3	Silicon	0.741	7.8
Copper	0.388	16.5	Silver	0.235	19.5
Glass	0.896	9.0	Steel (mild)	0.494	12.0
Gold	0.130	14.2	Tin	0.230	26.7
Ice (between -20°C and 0°C)	2.135	50.4	Zinc	0.389	16.5

SPECIFIC HEAT and VOLUME EXPANSION FOR LIQUIDS

Liquid	Specific Heat (at 20°C) kJ/kgK or kJ/kg °C	Coefficient of Volume Expansion (Multiply by 10 ⁻⁴)	Liquid	Specific Heat (at 20°C) kJ/kgK or kJ/kg °C	Coefficient of Volume Expansion (Multiply by 10 ⁻⁴)
Alcohol (ethyl)	2.470	11.0	Olive Oil	1.633	
Ammonia	0.473		Petroleum	2.135	
Benzene	1.738	12.4	Gasoline	2.093	12.0
Carbon Dioxide	3.643	1.82	Turpentine	1.800	9.4
Mercury	0.139	1.80	Water	4.183	3.7

Chemical Heating Value of a Fuel

$$\text{Chemical Heating Value MJ per kg of fuel} = 33.7 C + 144 \left(H_2 - \frac{O_2}{8} \right) + 9.3 S$$

C is the mass of carbon per kg of fuel

H₂ is the mass of hydrogen per kg of fuel

O₂ is the mass of oxygen per kg of fuel

S is the mass of sulphur per kg of fuel

Theoretical Air Required to Burn Fuel

$$\text{Air (kg per kg of fuel)} = \left[\frac{8}{3} C + 8 \left(H_2 - \frac{O_2}{8} \right) + S \right] \frac{100}{23}$$

Air Supplied from Analysis of Flue Gases

$$\text{Air in kg per kg of fuel} = \frac{N_2}{33 (CO_2 + CO)} \times C$$

C is the percentage of carbon in fuel by mass

N₂ is the percentage of nitrogen in flue gas by volume

CO₂ is the percentage of carbon dioxide in flue gas by volume

CO is the percentage of carbon monoxide in flue gas by volume

Boiler Formulae

$$\text{Equivalent evaporation} = \frac{\dot{m}_s (h_1 - h_2)}{2257 \text{ kJ/kg}}$$

$$\text{Factor of evaporation} = \frac{(h_1 - h_2)}{2257 \text{ kJ/kg}}$$

$$\text{Boiler efficiency} = \frac{\dot{m}_s (h_1 - h_2)}{\dot{m}_f \times \text{calorific value of fuel}}$$

where \dot{m}_s = mass flow rate of steam

h_1 = enthalpy of steam produced in boiler

h_2 = enthalpy of feedwater to boiler

\dot{m}_f = mass flow rate of fuel

FLUID MECHANICS

Discharge from an Orifice

$$\begin{aligned}\text{Let } A &= \text{cross-sectional area of the orifice} = (\pi/4)d^2 \\ \text{and } A_c &= \text{cross-sectional area of the jet at the vena contracta} = ((\pi/4) d_c^2) \\ \text{then } A_c &= C_c A \\ \text{or } C_c &= \frac{A_c}{A} = \left(\frac{d_c}{d}\right)^2\end{aligned}$$

where C_c is the coefficient of contraction

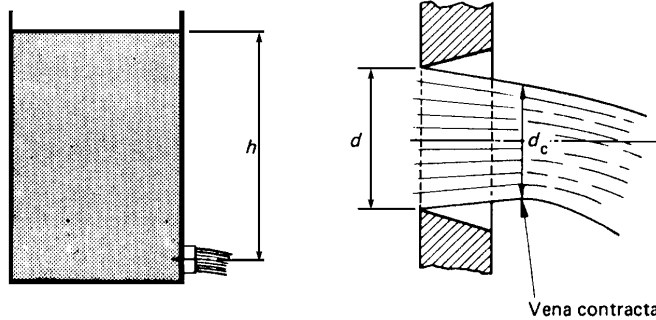

At the vena contracta, the volumetric flow rate Q of the fluid is given by

$$\begin{aligned}Q &= \text{area of the jet at the vena contracta} \times \text{actual velocity} \\ &= A_c v \\ \text{or } Q &= C_c A C_v \sqrt{2gh}\end{aligned}$$

The coefficients of contraction and velocity are combined to give the coefficient of discharge, C_d

$$\begin{aligned}\text{i.e. } C_d &= C_c C_v \\ \text{and } Q &= C_d A \sqrt{2gh}\end{aligned}$$

Typically, values for C_d vary between 0.6 and 0.65

$$\text{Circular orifice: } Q = 0.62 A \sqrt{2gh}$$

Where Q = flow (m^3/s) A = area (m^2) h = head (m)

$$\text{Rectangular notch: } Q = 0.62 (B \times H) \frac{2}{3} \sqrt{2gh}$$

Where B = breadth (m) H = head (m above sill)

$$\text{Triangular Right Angled Notch: } Q = 2.635 H^{5/2}$$

Where H = head (m above sill)

Bernoulli's Theory

$$H = h + \frac{P}{w} + \frac{v^2}{2g}$$

H = total head (metres)

w = force of gravity on 1 m³ of fluid (N)

h = height above datum level (metres)

v = velocity of water (metres per second)

P = pressure (N/m² or Pa)

Loss of Head in Pipes Due to Friction

$$\text{Loss of head in metres} = f \frac{L}{d} \frac{v^2}{2g}$$

L = length in metres

v = velocity of flow in metres per second

d = diameter in metres

f = constant value of 0.01 in large pipes to 0.02 in small pipes

Note: This equation is expressed in some textbooks as

$$\text{Loss} = 4f \frac{L}{d} \frac{v^2}{2g} \text{ where the } f \text{ values range from } 0.0025 \text{ to } 0.005$$

Actual Pipe Dimensions

Schedule 40 (SI Units)

Nominal Pipe Size (in)	Outside Diameter (mm)	Inside Diameter (mm)	Wall Thickness (mm)	Flow Area (m ²)
$\frac{1}{8}$	10.3	6.8	1.73	3.660×10^{-5}
$\frac{1}{4}$	13.7	9.2	2.24	6.717×10^{-5}
$\frac{3}{8}$	17.1	12.5	2.31	1.236×10^{-4}
$\frac{1}{2}$	21.3	15.8	2.77	1.960×10^{-4}
$\frac{3}{4}$	26.7	20.9	2.87	3.437×10^{-4}
1	33.4	26.6	3.38	5.574×10^{-4}
$1\frac{1}{4}$	42.2	35.1	3.56	9.653×10^{-4}
$1\frac{1}{2}$	48.3	40.9	3.68	1.314×10^{-3}
2	60.3	52.5	3.91	2.168×10^{-3}
$2\frac{1}{2}$	73.0	62.7	5.16	3.090×10^{-3}
3	88.9	77.9	5.49	4.768×10^{-3}
$3\frac{1}{2}$	101.6	90.1	5.74	6.381×10^{-3}
4	114.3	102.3	6.02	8.213×10^{-3}
5	141.3	128.2	6.55	1.291×10^{-2}
6	168.3	154.1	7.11	1.864×10^{-2}
8	219.1	202.7	8.18	3.226×10^{-2}
10	273.1	254.5	9.27	5.090×10^{-2}
12	323.9	303.2	10.31	7.219×10^{-2}
14	355.6	333.4	11.10	8.729×10^{-2}
16	406.4	381.0	12.70	0.1140
18	457.2	428.7	14.27	0.1443
20	508.0	477.9	15.06	0.1794
24	609.6	574.7	17.45	0.2594

ELECTRICITY

Ohm's Law

$$I = \frac{E}{R}$$

or $E = IR$

where I = current (amperes)
 E = electromotive force (volts)
 R = resistance (ohms)

Conductor Resistivity

$$R = \rho \frac{L}{a}$$

where ρ = specific resistance (or resistivity) (ohm metres, $\Omega \cdot m$)
 L = length (metres)
 a = area of cross-section (square metres)

Temperature correction

$$R_t = R_o (1 + \alpha t)$$

where R_o = resistance at 0°C (Ω)
 R_t = resistance at $t^\circ\text{C}$ (Ω)
 α = temperature coefficient which has an average value for copper of 0.004 28 ($\Omega/\Omega^\circ\text{C}$)

$$R_2 = R_1 \frac{(1 + \alpha t_2)}{(1 + \alpha t_1)}$$

where R_1 = resistance at t_1 (Ω)
 R_2 = resistance at t_2 (Ω)

α Values	$\Omega/\Omega^\circ\text{C}$
copper	0.00428
platinum	0.00385
nickel	0.00672
tungsten	0.0045
aluminum	0.0040

Dynamo Formulae

$$\text{Average e.m.f. generated in each conductor} = \frac{2\Phi NpZ}{60c}$$

where Z = total number of armature conductors

c = number of parallel paths through winding between positive and negative brushes

where $c = 2$ (wave winding), $c = 2p$ (lap winding)

Φ = useful flux per pole (webers), entering or leaving the armature

p = number of pairs of poles

N = speed (revolutions per minute)

$$\text{Generator Terminal volts} = E_G - I_a R_a$$

$$\text{Motor Terminal volts} = E_B + I_a R_a$$

where E_G = generated e.m.f.

E_B = generated back e.m.f.

I_a = armature current

R_a = armature resistance

Alternating Current

R.M.S. value of sine curve = 0.707 maximum value

Mean value of sine curve = 0.637 maximum value

$$\text{Form factor of sinusoidal} = \frac{\text{R.M.S. value}}{\text{Mean value}} = \frac{0.707}{0.637} = 1.11$$

$$\text{Frequency of alternator} = \frac{pN}{60} \text{ cycles per second}$$

Where p = number of pairs of poles

N = rotational speed in r/min

Slip of Induction Motor

$$\frac{\text{Slip speed of field} - \text{speed of rotor}}{\text{Speed of field}} \times 100$$

Inductive Reactance

$$\text{Reactance of AC circuit (X)} = 2\pi fL \text{ ohms}$$

where L = inductance of circuit (henries)

$$\text{Inductance of an iron cored solenoid} = \frac{1.256T^2\mu A}{L \times 10^8} \text{ henries}$$

where T = turns on coil

μ = magnetic permeability of core

A = area of core (square centimetres)

L = length (centimetres)

Capacitance Reactance

$$\text{Capacitance reactance of AC circuit} = \frac{1}{2\pi fC} \text{ ohms}$$

where C = capacitance (farads)

$$\text{Total reactance} = \left(2\pi fL - \frac{1}{2\pi fC} \right) \text{ ohms}$$

$$\text{Impedance (Z)} = \sqrt{(\text{resistance})^2 + (\text{reactance})^2}$$

$$= \sqrt{R^2 + \left(2\pi fL - \frac{1}{2\pi fC} \right)^2} \text{ ohms}$$

Current in AC Circuit

$$\text{Current} = \frac{\text{impressed volts}}{\text{impedance}}$$

Power Factor

$$\text{p.f.} = \frac{\text{true watts}}{\text{volts} \times \text{amperes}}$$

also p.f. = $\cos \Phi$, where Φ is the angle of lag or lead

Three Phase Alternators

Star connected

$$\text{Line voltage} = \sqrt{3} \times \text{phase voltage}$$

$$\text{Line current} = \text{phase current}$$

Delta connected

$$\text{Line voltage} = \text{phase voltage}$$

$$\text{Line current} = \sqrt{3} \times \text{phase current}$$

Three phase power

$$P = \sqrt{3} E_L I_L \cos \Phi$$

$$E_L = \text{line voltage}$$

$$I_L = \text{line current}$$

$$\cos \Phi = \text{power factor}$$

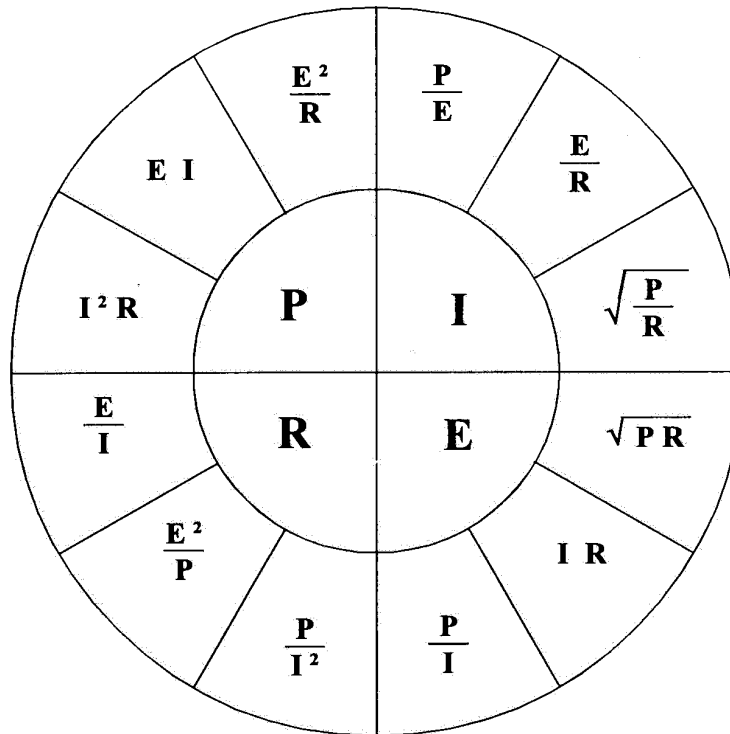



PERIODIC TABLE OF THE ELEMENTS

Group	1 IA	2 IIA	3 IIIB	4 IVB	5 VB	6 VIB	7 VIIB	8 VIII B	9 VIII B	10 VIII B	11 IB	12 IIB	13 IIIA	14 IVA	15 VA	16 VIA	17 VIIA	18 VIIIA									
	1 H 1.008	Alkaline Earth Metals ↓ 2 He 4.003	Noble Gases																								
	3 Li 6.941	4 Be 9.012	Transition Metals																								
	11 Na 22.99	12 Mg 24.31	Alkali Metals																								
	19 K 39.10	20 Ca 40.08	21 Sc 44.96	22 Ti 47.88	23 V 50.94	24 Cr 52.00	25 Mn 54.94	26 Fe 55.85	27 Co 58.93	28 Ni 58.69	29 Cu 63.55	30 Zn 65.38	31 Ga 69.72	32 Ge 72.59	33 As 74.92	34 Se 78.96	35 Br 79.90	36 Kr 83.80									
	37 Rb 85.47	38 Sr 87.62	39 Y 88.91	40 Zr 91.22	41 Nb 92.91	42 Mo 95.94	43 Tc (98)	44 Ru 101.1	45 Rh 102.9	46 Pd 106.4	47 Ag 107.9	48 Cd 112.4	49 In 114.8	50 Sn 118.7	51 Sb 121.8	52 Te 127.6	53 I 126.9	54 Xe 131.3									
	55 Cs 132.9	56 Ba 137.3	57 La* 138.9	72 Hf 178.5	73 Ta 180.9	74 W 183.9	75 Re 186.2	76 Os 190.2	77 Ir 192.2	78 Pt 195.1	79 Au 197.0	80 Hg 200.6	81 Tl 204.4	82 Pb 207.2	83 Bi 209.0	84 Po (209)	85 At (210)	86 Rn (222)									
	87 Fr (223)	88 Ra 226	89 Ac* (227)	104 Unq	105 Unp	106 Unh	107 Uns	108 Uno	109 Une	metals									nonmetals								
			* Lanthanides		58 Ce 140.1		59 Pr 140.9	60 Nd 144.2	61 Pm (145)	62 Sm 150.4	63 Eu 152.0	64 Gd 157.3	65 Tb 158.9	66 Dy 162.5	67 Ho 164.9	68 Er 167.3	69 Tm 168.9	70 Yb 173.0	71 Lu 175.0								
			* Actinides		90 Th 232.0		91 Pa (231)	92 U 238.0	93 Np (237)	94 Pu (244)	95 Am (243)	96 Cm (247)	97 Bk (247)	98 Cf (251)	99 Es (252)	100 Fm (257)	101 Md (258)	102 No (259)	103 Lr (260)								

ION NAMES AND FORMULAE

MONATOMIC

Ag^+	silver ion
Al^{3+}	aluminum ion
Au^+ and Au^{2+}	gold ion
Be^{2+}	beryllium ion
Ca^{2+}	calcium ion
Co^{2+} and Co^{3+}	cobalt ion
Cr^{2+} and Cr^{3+}	chromium ion
Cu^+ and Cu^{2+}	copper ion
Fe^{2+} and Fe^{3+}	iron ion
K^+	potassium ion
Li^+	lithium ion
Mg^{2+}	magnesium ion
Na^+	sodium ion
Zn^{2+}	zinc ion

POLYATOMIC

BO_3^{3-}	borate ion
$\text{C}_2\text{H}_3\text{O}_2^-$	acetate ion
ClO^-	hypochlorite ion
ClO_2^-	chlorite ion
ClO_3^-	chlorate ion
ClO_4^-	perchlorate ion
CN^-	cyanide ion
CO_3^{2-}	carbonate ion
$\text{C}_2\text{O}_4^{2-}$	oxalate ion
CrO_4^{2-}	chromate ion
$\text{Cr}_2\text{O}_7^{2-}$	dichromate ion
HCO_3^-	hydrogen carbonate or bicarbonate ion
H_3O^+	hydronium ion
HPO_4^{2-}	hydrogen phosphate ion
H_2PO_4^-	dihydrogen phosphate ion
HSO_3^-	hydrogen sulphite or bisulphite ion
HSO_4^-	hydrogen sulphate or bisulphate ion
MnO_4^-	permanganate ion
N_3^-	azide ion
NH_4^+	ammonium ion
NO_2^-	nitrite ion
NO_3^-	nitrate ion
O_2^{2-}	peroxide ion
OCN^-	cyanate ion
OH^-	hydroxide ion
PO_3^{3-}	phosphite ion
PO_4^{3-}	phosphate ion
SCN^-	thiocyanate ion
SO_3^{2-}	sulphite ion
SO_4^{2-}	sulphate ion
$\text{S}_2\text{O}_3^{2-}$	thiosulphate ion

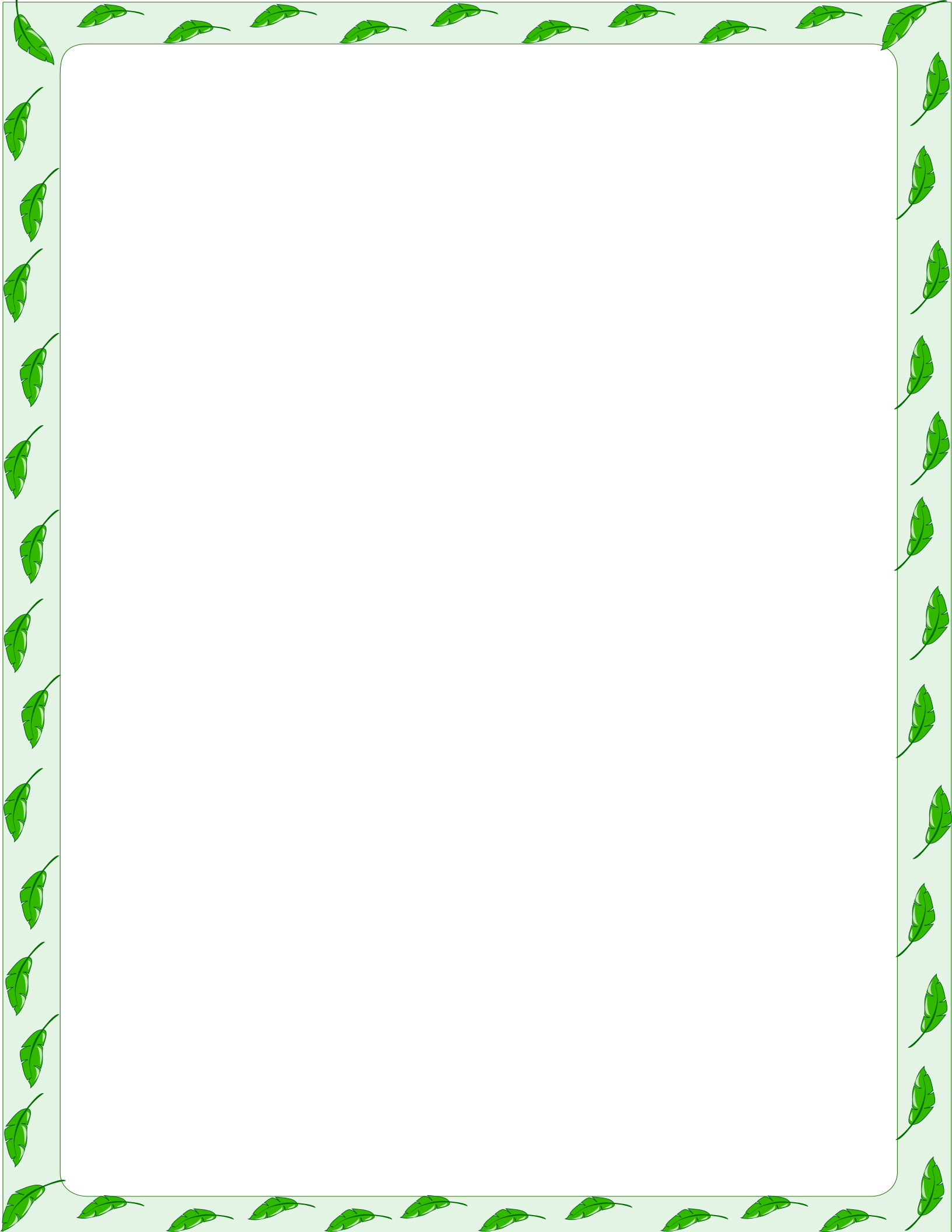

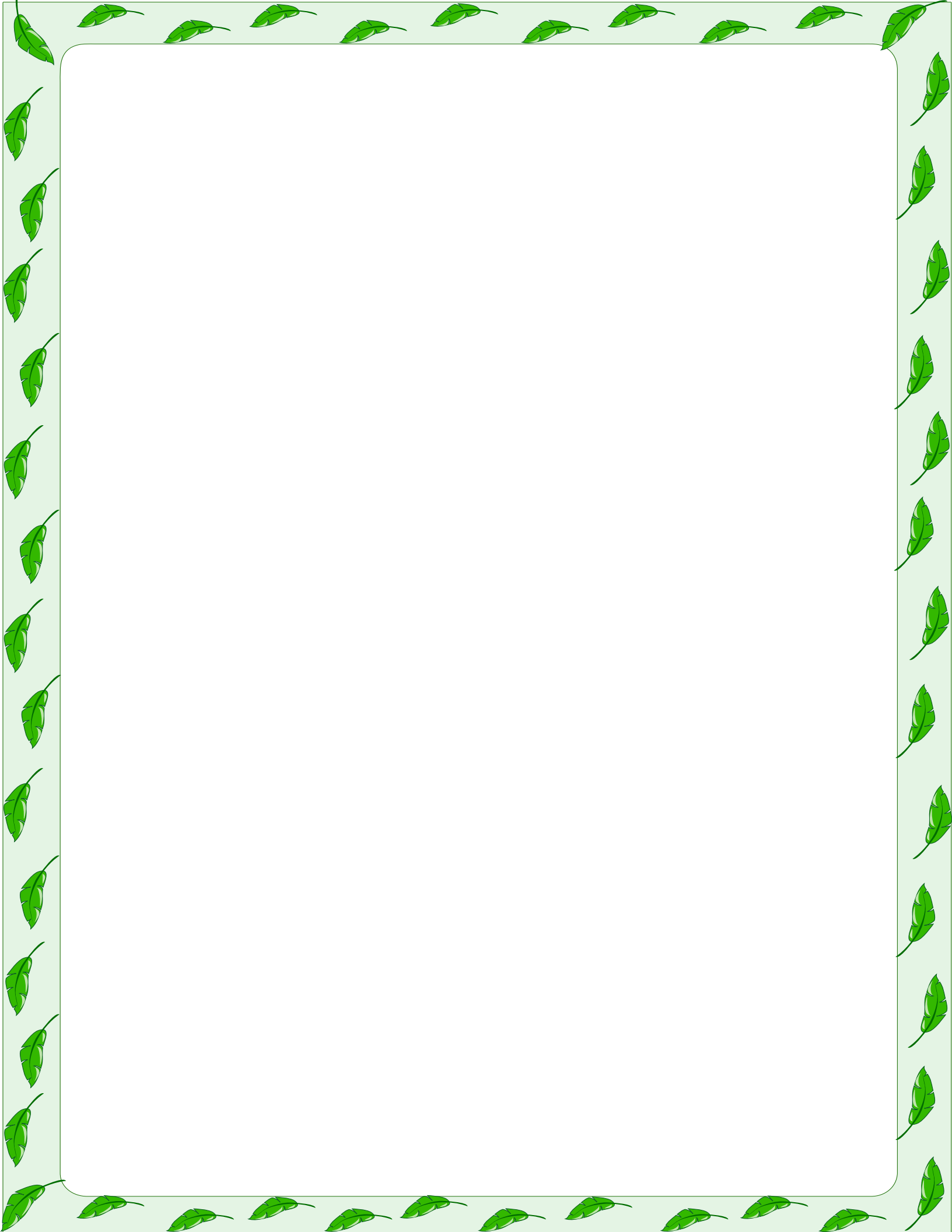

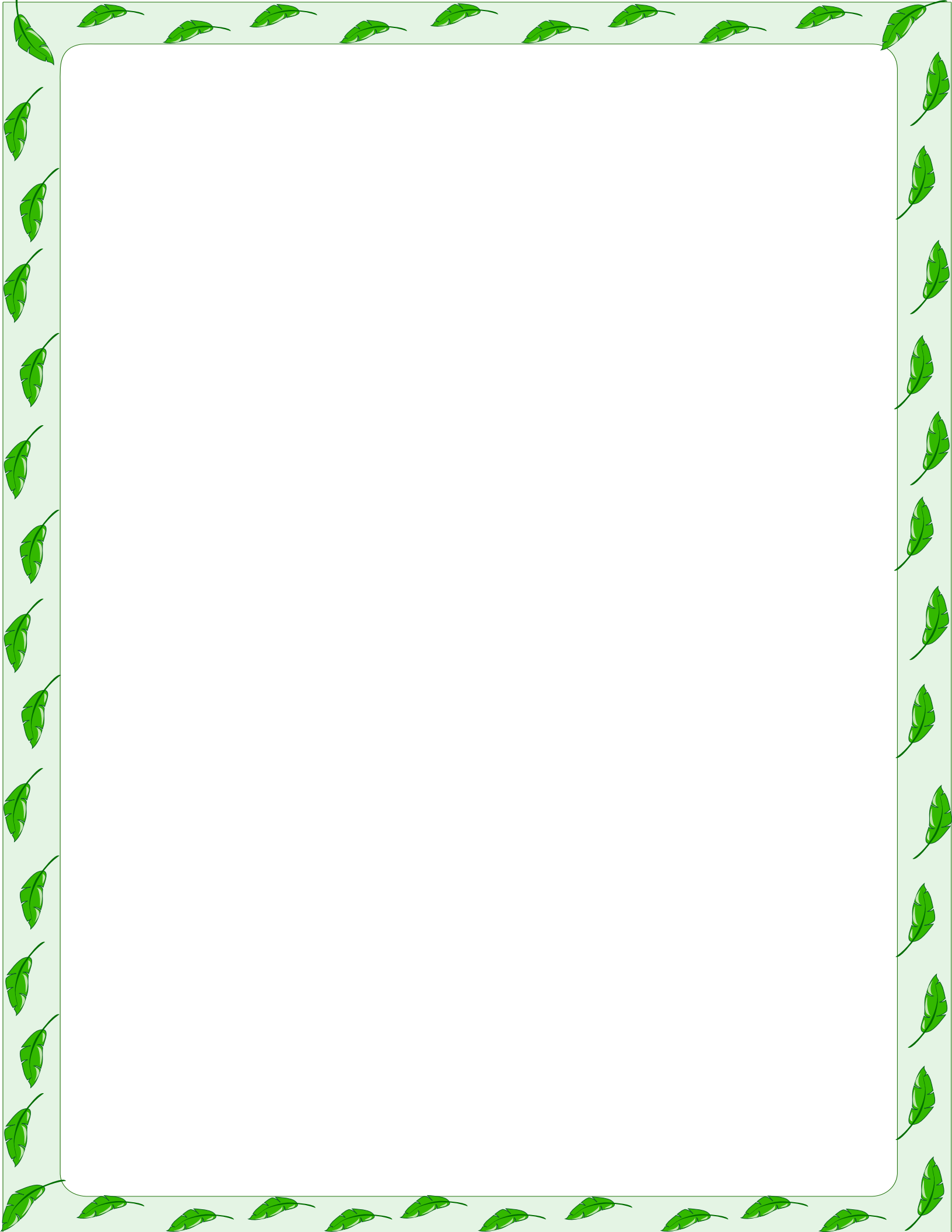

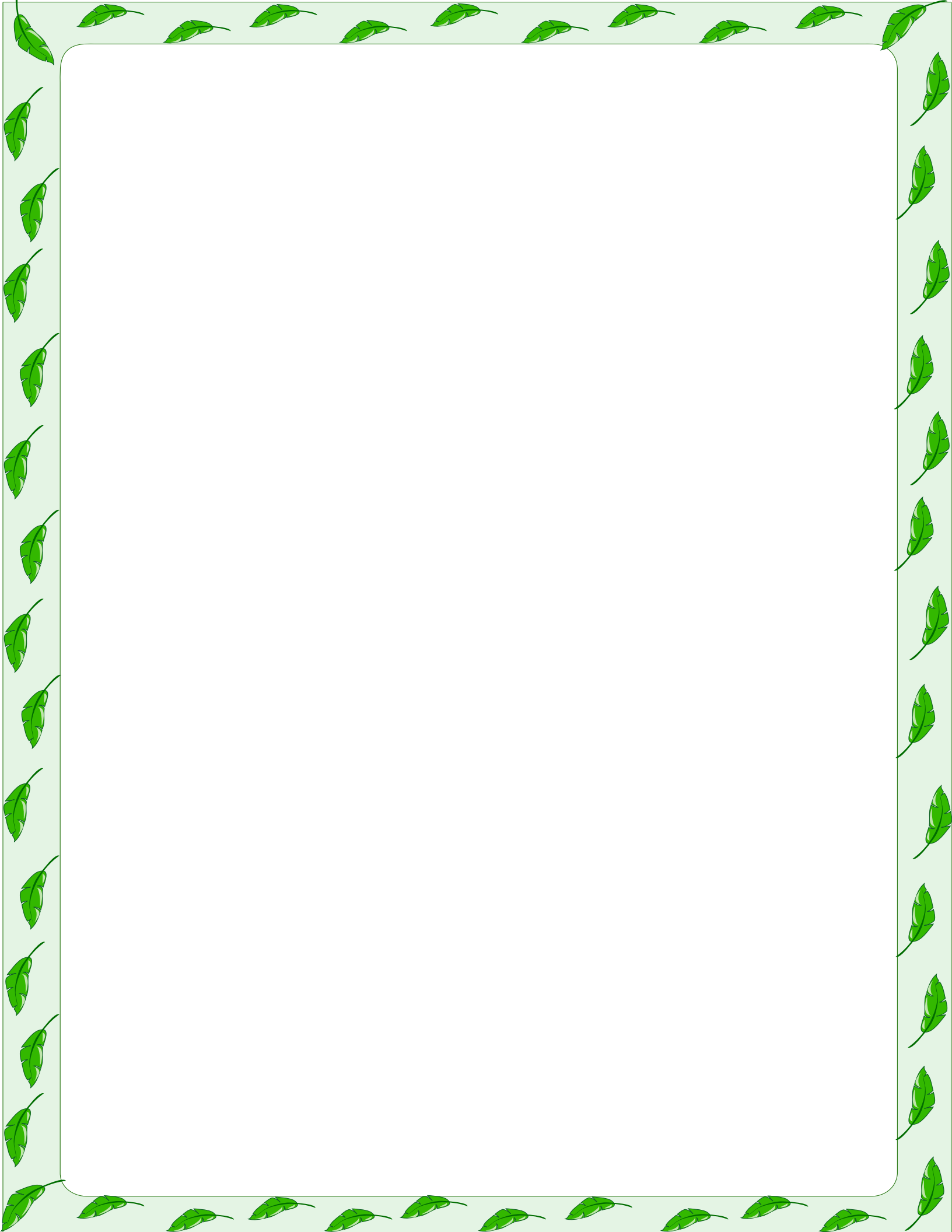



This material is owned by Power Engineering Training Systems and may not be modified from its original form. Duplication of this material for student use in-class or for examination purposes is permitted without written approval.



Address all inquiries to:

Power Engineering Training Systems
1301 – 16 Ave. NW, Calgary, AB Canada T2M 0L4
1-866-256-8193



Printed in Canada
on Recycled Paper